



No. 23E REFRIGERATION BURNER

The world's best absorption refrigerators incorporate this Aladdin burner that is renowned for its quality, reliable operation, and fuel economy.

This high quality burner is ideal for kerosene refrigerators with capacities between 115 and 225 liters (4 to 8 cubic feet).

SPECIFICATIONS:

Consumption (kerosene) 45 – 85 cc/hour
1.5 – 2.9 oz/hour

Heat Output 1,480 – 2,790 B.T.U./hour

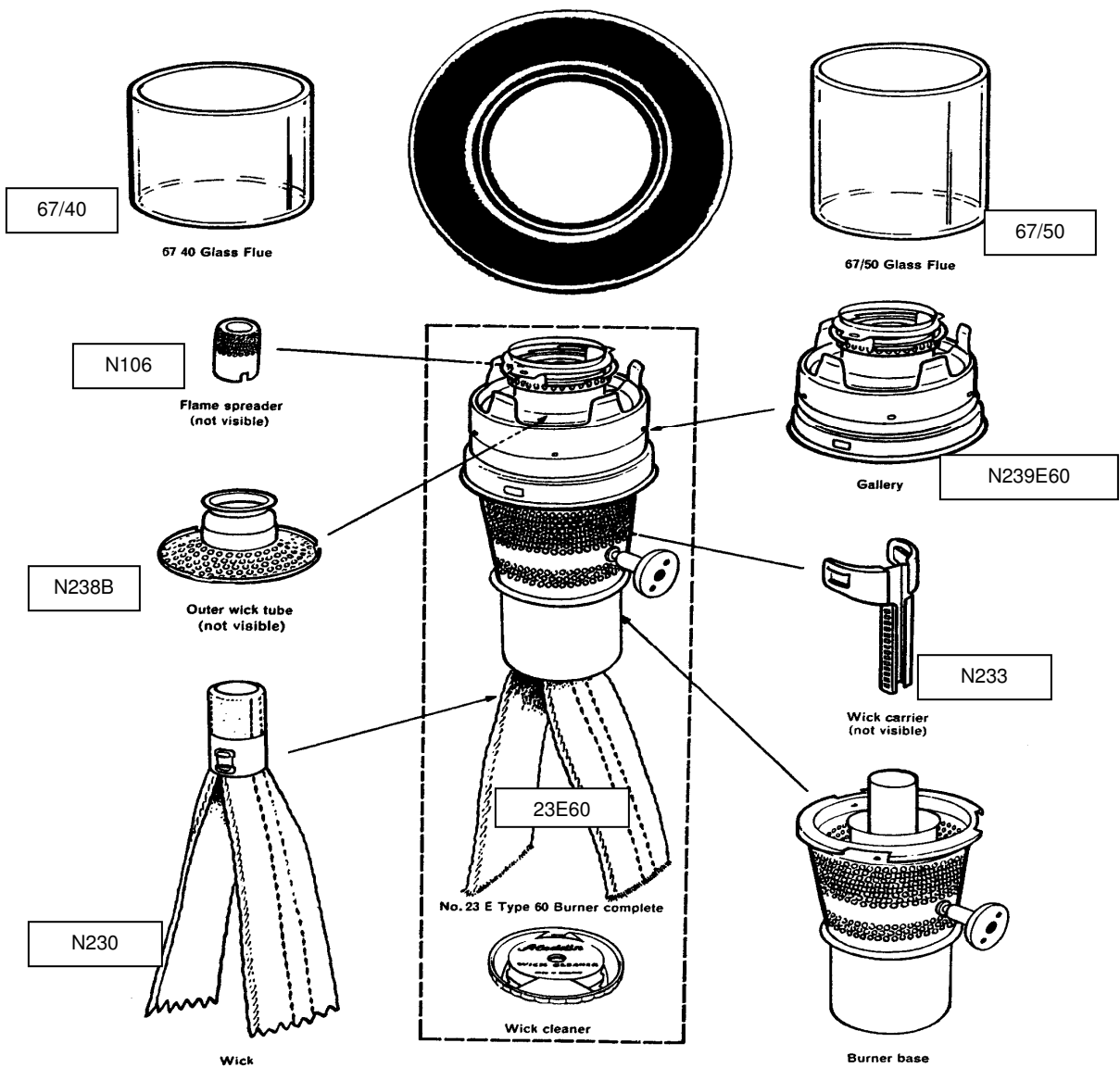

Aladdin Mantle Lamp Company

681 International Blvd
Clarksville, TN 37040 USA

Tel: 931-647-4949 Fax: 931-647-4517 e-mail 'sales@aladdinlamps.com'

The trademark ALADDIN is used under license from Aladdin Industries LLC